

**KITCHEN QUEEN**

Owner's Manual

The  
**Kitchen  
Queen  
Stove**

*"Wood energy at its best."*

Thank you for purchasing a Kitchen Queen Cookstove.

We hope you enjoy many years trouble-free service from your new Kitchen Queen Cookstove!

 **Obadiah's**  
800-968-8604  
249 Silver Dr. Troy, MT 59935  
[www.woodstoves.net](http://www.woodstoves.net) [www.stove-parts.net](http://www.stove-parts.net)

**SAVE THESE  
INSTRUCTIONS**

# !! CAUTION !!

- Hot while in operation. Keep children, clothing and furniture away. May cause skin burns.
- DO NOT use chemicals or fluids to start the fire.
- DO NOT burn garbage or flammable liquids.
- DO NOT connect to any air distribution duct or system.
- This stove is designed to burn wood only. DO NOT burn coal, pellets or any other type of fuel.
- **DO NOT REDUCE THE STOVE PIPE FROM THE STOVE TO THE CHIMNEY.** Model 480 must have a 7-inch pipe and Model 380 must have a 6-inch pipe. DO NOT COMPROMISE.
- The stove must be set on a fire-rated stove board. It must extend 16 inches (450 mm Canada) beyond the front and 8 inches (200 mm) beyond each side of the fuel loading and ash removing opening(s), and under the chimney connector and 2 inches (50 mm) beyond each side.
- The fuelling and ash removal doors must remain closed when the stove is in operation.

## CLEARANCE TO COMBUSTIBLES

Appliance Clearances	Unprotected Surfaces			Protected Surfaces (MFPA-211)		
	Parallel		Corner	Parallel		Corner
	Side	Rear		Side	Rear	
	18-in	36-in*	25-in	12-in	12-in	9-in

\*For clearances to the flue collar, subtract 6.5 in

Chimney Connector	Unprotected Surfaces	Protected Surfaces (MFPA-211)
		18-in

To reduce clearances, a wall protector must be used with a 1" air space behind the protector and at least 1" off the floor. The protector should extend 8" beyond the sides and top of the stove, not counting the back and shelf.

## STARTING YOUR FIRST FIRE

The stove top is treated with an anti-rust agent. Using a good degreaser and water, thoroughly wash the top before starting a fire.

Open the direct smoke outlet all the way by moving the handle in the back all the way to the left. This will allow smoke and gases to travel directly into the chimney. This will increase the draft to the firebox and reduce the tendency to smoke while the chimney is still cold.

Open the draft control on the door all the way. Also open the supercharger by pulling the handle under the safety shelf all the way out. Now the stove is wide open.

# INSTRUCTIONS

## Assembly and Installation for Models 480 and 380

- 1) Remove the stove from shipping crate (if crated) by removing the three leg bolts. Remove all wooden or paper packaging material being careful not to pry against the sides of the stove as scratching or chipping may result.
- 2) Inspect the stove for possible damage and notify your freight carrier immediately if any damage has occurred.
- 3) Remove all loose parts from the firebox and oven.
- 4) The firebrick, doors, and lids can be removed to make the stove lighter for moving.
- 5) Move your Kitchen Queen to the desired location.
- 6) The left rear leg is adjustable. Screw the adjusting bolt down until the stove stands solid.
- 7) Fasten the stainless steel rods to the front and sides of the stove using the 1-1/4 spacers and secure with the 6 1/4 x 2-1/2 stove bolts. The bolts and spacers are inside the long rod.
- 8) The shelf under the firebox and oven doors is installed by sliding it into the slots under the stove. You might have to use a wood block to tap it into place.
- 9) Be sure to understand your new stove instructions by reading them over several times. Installation must comply with all local and national building codes. **The proper authorities (i.e.: the municipal building department, fire department or fire prevention bureau) should be consulted before installation to determine the need to obtain a permit.** If the stove is not properly installed, a house fire may result. To reduce the risk of fire, follow the installation instructions. Failure to follow instructions may result in property damage, bodily injury or even death.
- 10) The steel 1/4 x 1-1/4 flue collar at the rear center of the stove accepts a 7 inch pipe for Model 480 and a 6 inch pipe for Model 380, crimped end down. Fasten the pipe using three screws through the holes in the collar and each adjoining section.
- 11) Do not connect this unit to a chimney serving another appliance. A chimney height of at least 15 feet measured from the floor on which the stove stands is required. The chimney must be in good condition and installed according to manufacturer's instructions. The stove must be connected to a chimney complying with the requirements for type HT (2100 degree F) chimneys per UL 103 or ULC S629 or a code approved masonry with a flue liner. The chimney size should not be less than or more than 3 times greater than the cross-sectional area of the flue collar.

## STARTING YOUR FIRST FIRE, CONT.

Place crumpled paper and kindling into the firebox just inside the door and light with a match. As soon as the fire is burning well, close the direct smoke outlet by pushing the handle in the back all the way down to the right. **DO NOT OVERHEAT YOUR STOVE.** If fire becomes too hot, reduce the draft accordingly. Always keep the direct smoke outlet **OPEN** when checking the fire and close immediately when you close the door.

Never use gasoline-type lantern fuel, kerosene, charcoal lighter fluid, or similar liquids to start or freshen up a fire in the stove. Keep all such liquids well away from the stove while in use.

## CREOSOTE AND NEED FOR REMOVAL

When wood is burned slowly, it produces tar and other organic vapors which combine with expelled moisture to form creosote. The creosote vapors condense in the relatively cool chimney flue of a slow-burning fire. As a result, creosote residues accumulate on the flue liner. When ignited, this creosote makes an extremely hot fire. The chimney connector and chimney should be inspected at least every 2 months during the heating season to determine if a creosote buildup has occurred.

## ASHES

Before adding more wood, you should rake the ashes with the poker to break up any clods and cause the fine ashes to sift down into the ash pan. Always allow several inches of ashes to remain on the grate. This will result in better efficiency and finer more cleanly burned-up ashes.

Ashes should be placed in a metal container with a tight-fitting lid. The closed container of ashes should be placed on a non-combustible floor or on the ground well away from all combustible material pending final disposal. If ashes are disposed of by burial in the soil, or otherwise locally disposed of, they should be retained in the closed container until all cinders have thoroughly cooled.

## USING THE OVEN

To heat the oven, be sure that the little handle on the right hand side of the stove is pulled all the way out. This will direct the heat around the oven. Open the drafts all the way until you have a nice hot fire then shut it down some, even if the temperature is not up to where you want it. It will keep going up, even after it is shut down some. The oven comes with two nickel plated racks that can be adjusted to any of four different locations to get the desired space. The bottom of the oven is removable and it can be used as a testing shelf.

If the oven does not respond properly, your chimney is most likely not drawing as it should or the space under the oven needs to be cleaned out. Check for obstructions that may be reducing your draft. Consulting a professional chimney sweep may be advisable.

## MAINTENANCE OF YOUR NEW STOVE

Clean the top daily. You may use soap and water for initial cleaning.

Follow up with emery cloth to maintain a smooth, glossy finish. The top will blue and finally turn black, which is normal. But if it is properly cared for, will remain smooth and shiny.

When the stove is not in use for more than a couple of days, coat with a light oil to prevent rust. It will rust if left uncoated when the stove is cold. The porcelain finish is easily cleaned with soap and water. **DO NOT CLEAN THE PORCELAIN WITH OVEN CLEANER, IT WILL RUIN THE FINISH.**

## SOME ADDITIONAL TIPS

Never reduce the stove pipe from the stove to the chimney. It will reduce the efficiency of the stove and you might have trouble getting the baker hot.

Avoid horizontal pipes as much as possible and keep them as short as you can. Sloping pipes are much better than flat.

When building a fire, always let the fire burn hot for awhile before shutting it down. This will help a lot in reducing creosote buildup and liquid creosote.

Using big pieces of wood will not burn fast or hot. Split them down some, at least. The wetter the wood, the smaller it must be split. Use the big chunks for overnight burns.

If the stove is not in use, coat it with a light oil and check it once in awhile to make sure it's not rusting.

### Determining the R Factor of Floor-Protector Material

An easy means of determining if a proposed floor protector meets the requirements is to follow this procedure.

- 1) Convert specifications to R-Value
  - a) R-value is given - no conversion is needed
  - b) K-factor is given with a required thickness (T in inches:  $R=1/kxt$ )
  - c) C-Factor is given:  $R=1/C$
- 2) Determine the R-value of the proposed alternate floor protector
  - a) Use the formula in step (1) to convert values not already expressed as "R"
  - b) For multiple layers, add R-values of each layer to determine the overall R value.
- 3) If the overall R-value of the system is greater than the R-value of the specified floor protector, the alternate is acceptable.

#### EXAMPLE:

The specified floor protector should be 3/4 inch thick material with a K-factor of 0.84. The proposed alternate is 4" brick with a C-factor of 1.25 over 1/8" mineral board with a K-factor of 0.29.

Step 1: Use the formula above to convert specifications to R-value.  $R=1/kxt=1/0.84 \times .75=0.893$

Step 2: Calculate R of proposed system.

4" brick of  $C=1.25$ , therefore  $R \text{ Brick}=1/C, 1.25=0.80$

1/8" mineral board of  $K=0.29$ , therefore  $R \text{ Mineral Board}=1/0.29 \times 0.125 = 0.431$

Total  $R = R \text{ Brick} + R \text{ Mineral Board} = 0.8 + 0.431 = 1.231$

Step 3: Compare proposed system R of 1.231 to specified R of 0.893. Since proposed system R is greater than required, the system is acceptable.

#### DEFINITIONS:

$$\text{Thermal Conductance} = C = \frac{\text{BTU}}{(\text{HR})(\text{FT}^2)(\text{°F})} = \frac{W}{(\text{M}^2)(\text{°K})}$$

$$\text{Thermal Conductivity} = K = \frac{(\text{BTU})(\text{inch})}{(\text{HR})(\text{FT}^2)(\text{°F})} = \frac{W}{(\text{M}^2)(\text{°K})} = \frac{\text{BTU}}{(\text{HR})(\text{FT}^2)(\text{°F})}$$

$$\text{Thermal Resistance} = R = \frac{(\text{FT}^2)(\text{HR})(\text{°F})}{\text{BTU}} = \frac{(\text{M}^2)(\text{°K})}{W}$$

# Chimney Connectors and Vent Connectors

Table 6-7.5 Chimney Connector Systems and Clearances from Combustible Walls for Residential Heating Appliances

System	Clearance (in.)/(mm)
<p><b>A</b> Minimum 3.5-in. (90-mm) thick brick masonry wall framed into combustible wall with a minimum of 12-in. (305-mm) brick separation from clay liner to combustibles. Fireclay liner (ASTM C 315, <i>Standard Specification for Clay Fire Linings</i>, or equivalent), minimum 1/4-in. (16-mm) wall thickness, shall run from outer surface of brick wall to, but not beyond, the inner surface of chimney flue liner and shall be firmly cemented in place.</p>	12/305
<p><b>B</b> Solid-insulated, listed factory-built chimney length of the same inside diameter as the chimney connector and having 1 in. (25.4 mm) or more of insulation with a minimum 9-in. (229-mm) air space between the outer wall of the chimney length and combustibles.</p> <p>The inner end of the chimney length shall be flush with the inside of the masonry chimney flue and shall be sealed to the flue and to the brick masonry penetration with non-water-soluble refractory cement. Supports shall be securely fastened to wall surfaces on all sides.</p> <p>Fasteners between supports and the chimney length shall not penetrate the chimney liner.</p>	9/229
<p><b>C</b> Sheet steel chimney connector, minimum 24 gauge [0.024 in. (0.61 mm)] in thickness, with a ventilated thimble, minimum 24 gauge [0.024 in. (0.61 mm)] in thickness, having two 1-in. (25.4-mm) air channels, separated from combustibles by a minimum of 6 in. (152 mm) of glass fiber insulation. Opening shall be covered, and thimble supported with a sheet steel support, minimum 24 gauge [0.024 in. (0.61 mm)] in thickness.</p> <p>Supports shall be securely fastened to wall surfaces on all sides and shall be sized to fit and hold chimney section. Fasteners used to secure chimney section shall not penetrate chimney flue liner.</p>	6/152
<p><b>D</b> Solid-insulated, listed factory-built chimney length with an inside diameter 2 in. (51 mm) larger than the chimney connector and having 1 in. (25 mm) or more of insulation, serving as a pass-through for a single wall sheet steel chimney connector of minimum 24 gauge [0.024 in. (0.61 mm)] thickness, with a minimum 2-in. (51-mm) air space between the outer wall of chimney section and combustibles.</p> <p>Minimum length of chimney section shall be 12 in. (305 mm). Chimney section concentric with and spaced 1 in. (25.4 mm) away from connector by means of sheet steel support plates on both ends of chimney section. Opening shall be covered, and chimney section supported on both sides with sheet steel supports of minimum 24 gauge [0.024 in. (0.61 mm)] thickness.</p> <p>Supports shall be securely fastened to wall surfaces on all sides and shall be sized to fit and hold chimney section. Fasteners used to secure chimney section shall not penetrate chimney flue liner.</p>	2/51

**Additional requirements:**

1. Insulation material used as part of wall pass-through system shall be of noncombustible material and shall have a thermal conductivity of 1.0 Btu-in./hr-ft<sup>2</sup>-F (4.88 kg-cal/cm<sup>2</sup>-D) or less.
2. All clearances and thicknesses are minimum; larger clearances and thicknesses shall be permitted.
3. Any material used to close up an opening for the connector shall be of noncombustible material.
4. A connector to a masonry chimney, except for System B, shall extend in one continuous piece through the wall pass-through system and the chimney wall to the inner face of the flue liner, but not beyond.

# Typical Factory-Built Masonry Chimney Installations

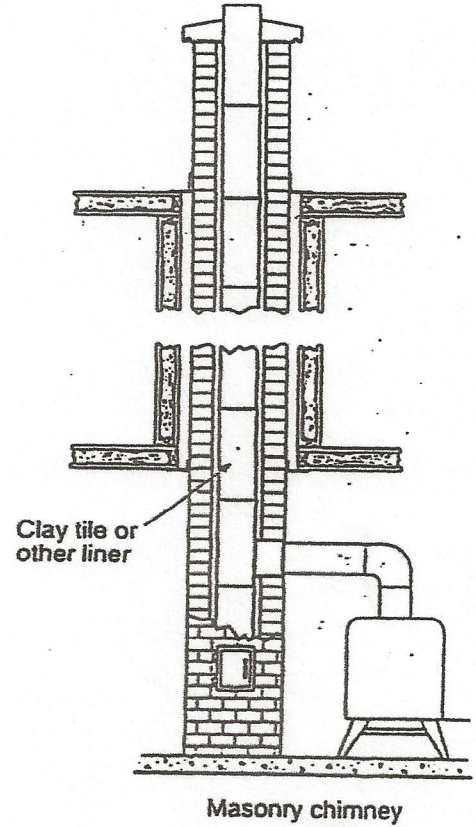
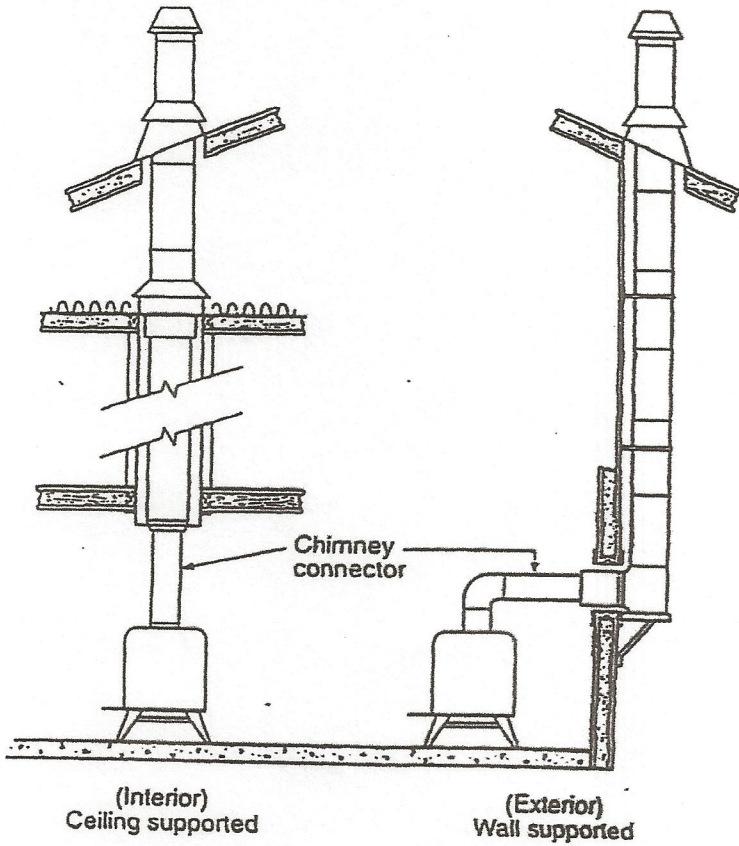

 **Obadiah's**  
800-968-8604  
249 Silver Dr. Troy, MT 59935  
[www.woodstoves.net](http://www.woodstoves.net) [www.stove-parts.net](http://www.stove-parts.net)

# REPLACEMENT PARTS LIST

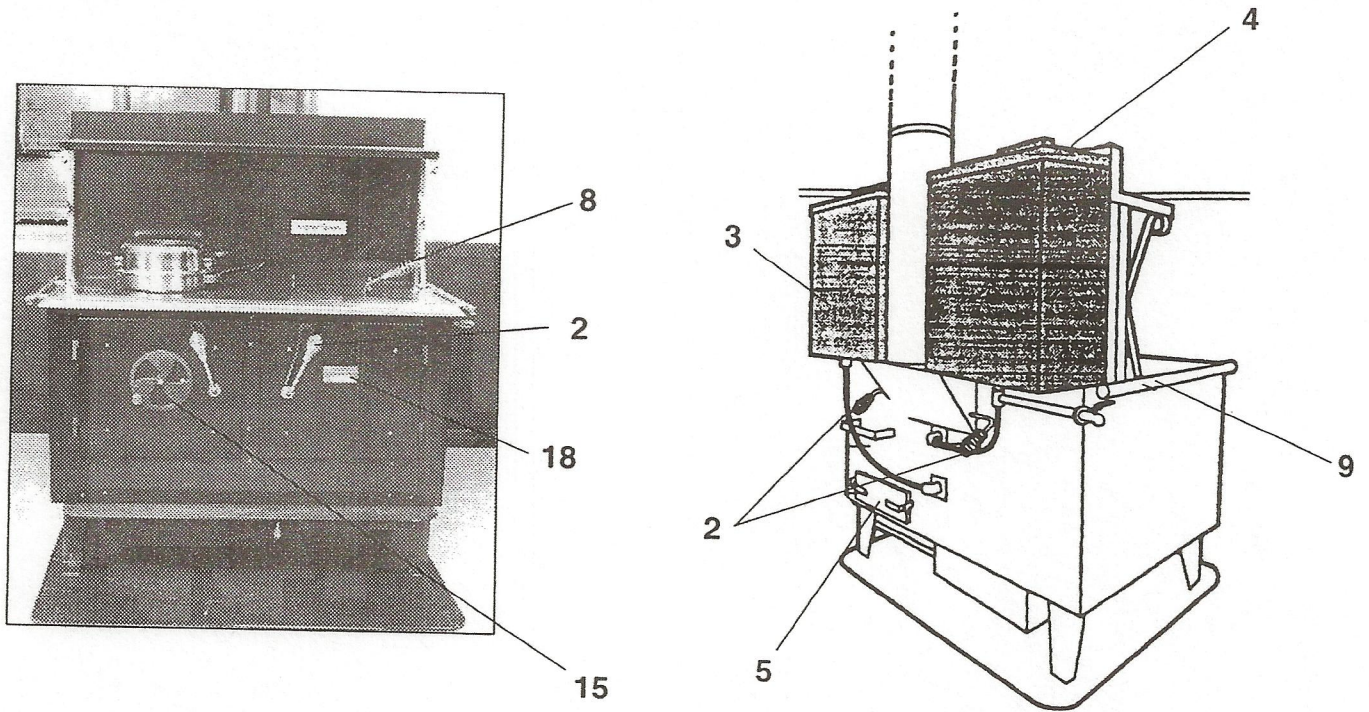

Item No	Order No.	Description
1	50	Gasket Set
2	52	Spring handles
3	54	Reservoir
4	56	Reservoir Lids
5	57	Cleanout Door
6	58	Grate
7	59	Poker
8	60	Lid Lifter
9	61	Safety Rails
10	62	Oven Racks
11	63	Firebricks
12	64	Sideshelf
13	65	Ashpan
14	66	Stove Lids
15	67	Draft Control
16	68	Shelf Bracket
17	69	Running Board
18	70	Oven Thermometer

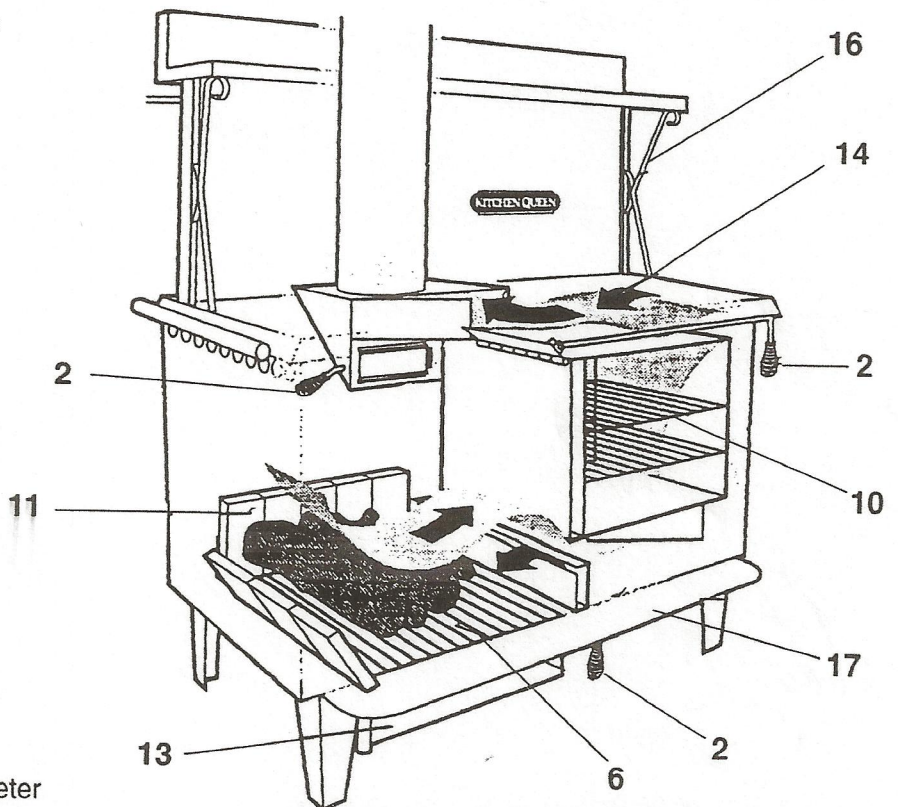

Specify Model 480 or 380 when ordering.